

(No Model.)

3 Sheets—Sheet 1

S. A. WOODS.

Cutter Head for Wood Working Machines.

No. 237,652.

Patented Feb. 8, 1881.

Fig. 1

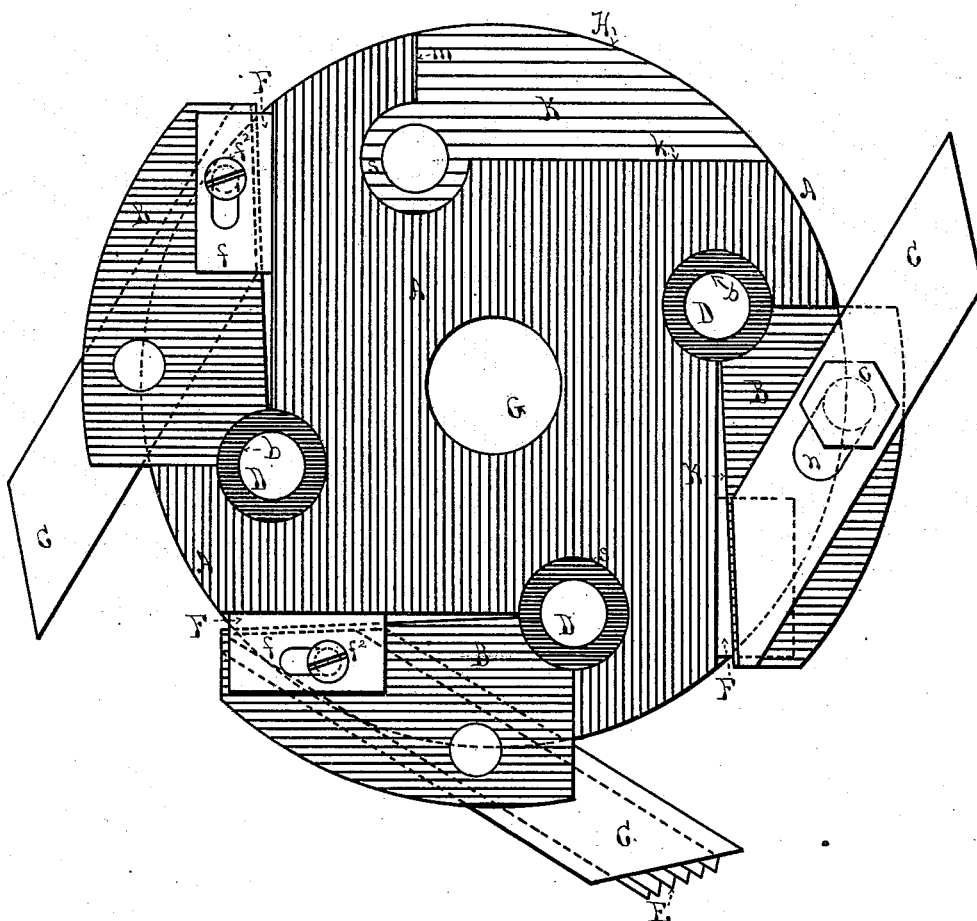

Witnesses

Wm. S. Brown
H. P. Dickinson

Inventor

S. A. Woods
By his Atty
Joseph C. Rice

(No Model.)

3 Sheets—Sheet 2.

S. A. WOODS.

Cutter Head for Wood Working Machines.
No. 237,652. Patented Feb. 8, 1881.

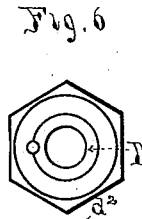
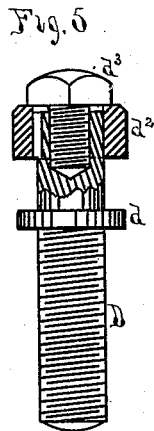
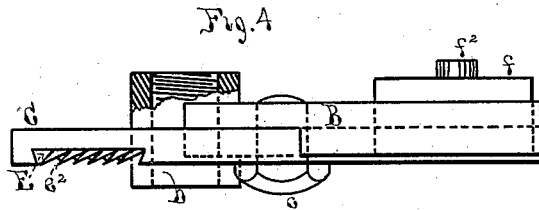
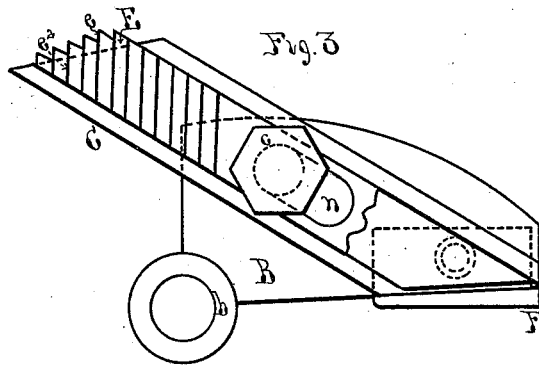
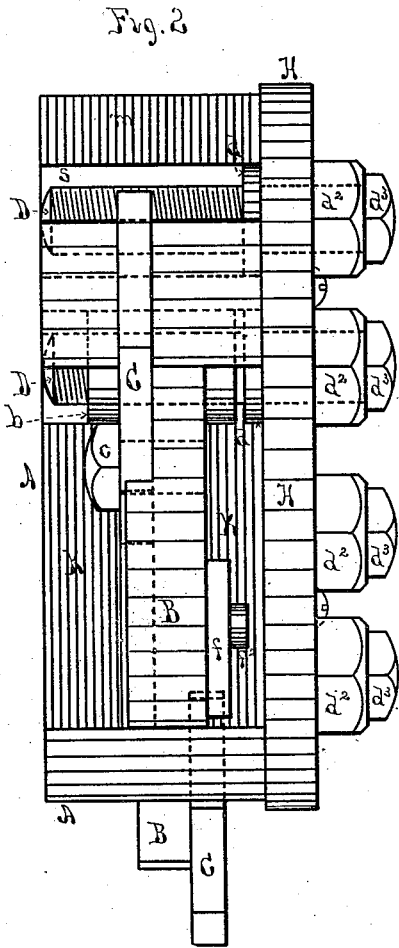

Witnesses

Wm. S. Brown
N. P. Ockington

Inventor

S. A. Woods
by H. H. Rice

(No Model.)

3 Sheets—Sheet 3.

S. A. WOODS.
Cutter Head for Wood Working Machines.
No. 237,652. Patented Feb. 8, 1881.

Fig. 7

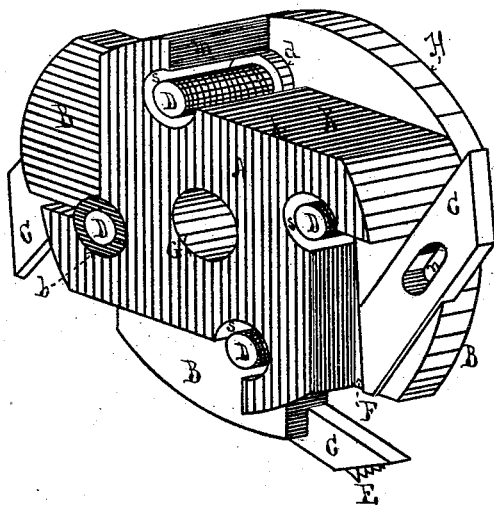

Witnesses

J. S. Brown
A. P. Ockington

Inventor.

S. A. Woods
by his Attorney *A. Rice*

UNITED STATES PATENT OFFICE.

SOLOMON A. WOODS, OF BOSTON, MASSACHUSETTS.

CUTTER-HEAD FOR WOOD-WORKING MACHINES.

SPECIFICATION forming part of Letters Patent No. 237,652, dated February 8, 1881.

Application filed May 21, 1880. (No model.)

To all whom it may concern:

Be it known that I, SOLOMON A. WOODS, of the city of Boston and State of Massachusetts, have invented a new and useful Cutter-Head for Planing-Machines, of which the following is a specification.

My improvement relates to rotary cutter-heads intended to carry cutters for cutting channels or grooves of any desired width in the surface of lumber or other materials; and the object of my invention is to provide a cutter-head having a cutter-stock which can be easily adjusted longitudinally in the cutter-head, while the cutter can be removed and replaced without altering that adjustment; to combine with such a cutter-head a cutter having a detachable adjustable serrated spur; to provide a cutter-head having cutters both radially and longitudinally adjustable, and one in which they can be adjusted either radially or longitudinally without disturbing their other adjustment. I attain these objects by the mechanism illustrated in the accompanying drawings, in which—

Figure 1 is a plan of the end of the cutter-head with one cutter-stock with its cutter removed. Fig. 2 is a side view of the same. Fig. 3 is a plan of cutter-stock removed from cutter-head. Fig. 4 is an edge view of same, partly in section. Fig. 5 is a view, partly in section, of adjusting-screw. Fig. 6 is an end elevation of end of the adjusting-screw with binding-screw removed. Fig. 7 is a perspective of the cutter-head with one cutter-stock attached.

Similar letters refer to similar parts throughout the several views.

A is the cutter-head; B B, the cutter-stocks having the cylindrical hubs *b b*; C C, the cutters; D D, the adjusting-screws; E E, the cutter-spurs; F F, the adjustable make-fit slides; G, the opening through the center of the head, through which the mandrel passes with which the cutter-head revolves.

s s are sockets formed in the cutter-head A.

K K are recesses formed in the head opening into the sockets *s s*, and having a floor or bottom, *k*, on a plane parallel with the axial line of the cutter-head, and a front retaining-edge, *m*, on a plane perpendicular to the bottom and parallel to the said axial line.

Attached to the head A is the plate H, through which, at points central to the sockets *s*, are swiveled the adjusting-screws D, which are firmly held in place by having upon them the collar *d* on one side of the plate and the splined polygonal collar *d*² on the other. As that part of the bolt D which extends through the plate H is shorter than the thickness of the splined collar, the binding-screw *d*³, tapped into the end of the adjusting-screw, will draw the collars *d* and *d*² together, and thus the adjusting-screw will be prevented from having any endwise movement in the socket *s*.

Fitting into the sockets *s* and recesses K are cutter-stocks B, which, being much thinner than the length of the sockets, can be placed and moved longitudinally a considerable distance in the sockets, so that each of the cutters C, attached to the cutter-stocks, can be adjusted to move in a path different from that of any of the others when the head is rotated, or the cutters can be made to follow one another in the same path, or any intermediate adjustment can be had.

In that part of the stock designated as the "hub *b*," fitting the sockets *s*, is a central opening having an internal thread engaging with the thread on the adjusting-screw D, so that when the parts are in place the stock B will be moved longitudinally in the socket and recess by turning the polygonal splined collar *d*², which moves the adjusting-screw D. As the bottom of the recess K is parallel with the axial line of the cutter-head such movement of the stock will not alter the distance from said line of the cutting-edge of the cutter attached to and moving with it, but will change the path in which the cutter travels when the head is rotated.

Attached to the cutters which cut the sides of the grooves or rabbets are serrated spurs E, which have their cutting-edges *e* backwardly inclined, so that the part nearest the surface of the lumber operated upon is most in advance, in order that the surface-corner next the groove shall not be injured by the chip removed by the cutter loosening or tearing out fibers of wood extending beyond the margin of the groove or rabbet being cut. This spur is also provided with serrations upon its side *e*², all cutting the lumber from the surface

downward, so that in working in cross-grained or knotty lumber or cutting channels across the grain of the lumber a groove shall be formed with smooth and finished side, and the surface corner of the lumber next the groove left perfect, instead of rough and broken, as is sometimes the case when a spur with a plain side is used. The spur and cutter are attached to the cutter-stock by a set-screw, *c*, which passes through the slotted hole *n* in the spur and cutter. By loosening this screw either or both can be adjusted radially without disturbing their adjustment longitudinally on the cutter-head.

The advantages of this construction are that if a cutter becomes dulled or broken it can readily be removed, sharpened, and replaced without regrinding those not injured, as must be done in a machine whose cutters are not radially adjustable, or a new cutter can be substituted without altering the adjustment of the machine for the work then in hand, and the cutters, being plain forgings without lathe-work, can be made by the operator of the machine with little difficulty; and if it be desired to cut very narrow or very wide grooves, cutters suitable for such purpose can be attached with little delay, and the capacity of the device is therefore greatly enlarged.

Under the heel of the cutter-stock B is placed the adjustable make-fit slide F, having a wing, *f*¹, through which a set-screw, *f*², passes in a slotted hole, so that when, from wear or other causes, the cutter-stock B does not perfectly fit the recess K, by driving the make-fit slide farther under the stock it will be tightened and all oscillation on the adjusting-screw prevented.

The operation of the device is as follows: The cutter-head having its cutters attached being rotated, (when placed in any machine adapted to receive it,) will cut a channel, groove, or rabbet of the width of one cutter if the cutters be all adjusted to follow in the same path, or a groove of any width up to the aggregate of the widths of the cutters can be cut by adjusting them so that each cutter shall cut in a path different from that of the others.

Heretofore the cutters for these adjustable cutter-heads have been made so that the adjusting-screws passed through a shank made to fit a cylindrical socket having a radial slot, through which the cutters formed with the shank reached out, as shown in Patent No. 188,221. This construction is objectionable, because the cutter extending out radially from

the cutter-head acts as a lever to increase the strain on the cutter at the periphery of the head, and it is consequently liable to frequent breakage at that point; and, as cutters so constructed cannot be adjusted radially, if one becomes dulled all must be ground to preserve an equal length, and if one has to be removed the adjustment longitudinally in the head is destroyed and must be again made.

With the construction shown in the patent the diameter of the cutter in the line of its rotation is limited by the diameter of the slot extending into the socket, which must be less than the socket; but in my device the dimensions of the cutter are in no way limited by the size of the socket. Therefore, in place of a device which had both limited strength and adjustability, I have provided one in which any desired adjustment can be made and any desired strength obtained.

What I claim as new and of my invention is—

1. In combination with the cutter-head A, provided with the socket *s*, the cutter-stock B, provided with the hub *b* and cutter C, and serrated spur E, substantially as described.

2. In combination with the cutter-head A, provided with the socket *s*, the adjusting-screw D, swiveled centrally in the socket and provided with the collar *d*¹, polygonal splined collar *d*², and binding-screw *d*³, substantially as described.

3. In combination, the cutter-head A, provided with recess K, the cutter-stock B, provided with make-fit slides F, and the adjusting-screw D, substantially as described.

4. In combination with a cutter-head provided with a recess whose floor is on a plane parallel with the axis of rotation of the head, a cutter-stock whose point of attachment to the head is at its forward part and whose rear-most point of support on the floor of the recess is as far from the place of attachment as is the edge of its attached cutter from such point, substantially as described.

5. In combination, the cutter-head A, provided with the socket *s* and recess K, the adjusting-screw D, cutter C, and stock B, resting upon the floor of the recess extending backward from the socket, and provided with the hub *b*, substantially as described.

SOLOMON A. WOODS.

Witnesses:

LEPINE C. RICE,
N. P. OCKINGTON.